



King 6:1 High-Flo[®] Pump

- **Pressure output capacity of 540 psi (3.7 MPa, 37 bar)**
- **Excellent abrasion and corrosion resistance using Graco SevereDuty™ wear parts**
- **Wetted parts of stainless steel and carbon steel to meet wide range of fluids**
- **Large porting for excellent priming and handling of high viscosity fluids without cavitation**
- **High volume displacement pump lower: few cycles per gallon for reduced wear**

**Reliable, low
shear 4-ball
paint circulating
pumps**

The best medium volume, low pressure performers for circulating supply of light to medium viscosity fluids. Driven by the reliable King air motor which is life tested to 10,000,000 cycles. These high volume circulating pumps will allow you to handle larger flow requirements while operating at low cycle rates. This will extend pump life and minimize the intervals for maintenance and repair. Overall cost of ownership is reduced by this extended pump life. These are all great reasons for choosing High-Flo pumps for your circulating and transfer applications.

Typical Fluids Handled **Stainless Steel Models**

- Waterborne paints
- Acid catalyzed varnishes, enamels, and lacquers

Carbon Steel Models

- Solventborne paints

Typical Applications

- Paint circulation, supply and transfer

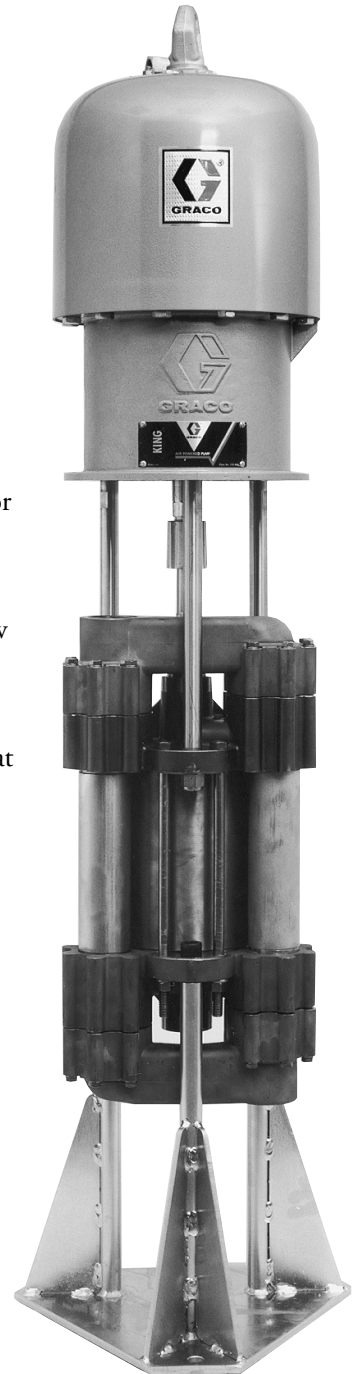

218-513
shown with stand mount
(218-742) not included

Technical Specifications

Maximum fluid pressure 540 psi (3.7 MPa, 37 bar)
Maximum air input pressure . . . 90 psi (0.63 MPa, 6.3 bar)
Fluid flow at 60 cpm 31 gpm (117 lpm)
Volume per cycle 0.5 gal. (1.89 liter)
Air inlet size 3/4 npsm(f)
Fluid inlet size 2 npt(f)
Fluid outlet size 2 npt(f)
Instruction manual 307-678

Dimensions

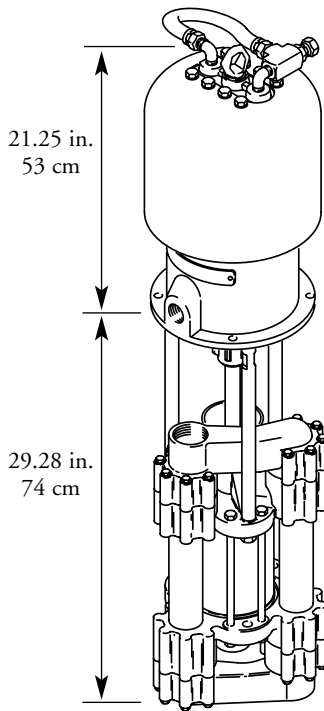

Mounting Hole Layout

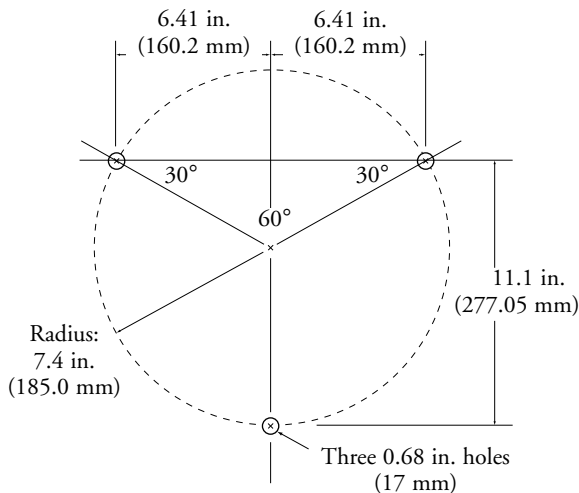

Performance Chart for King 6:1 High-Flo Pump

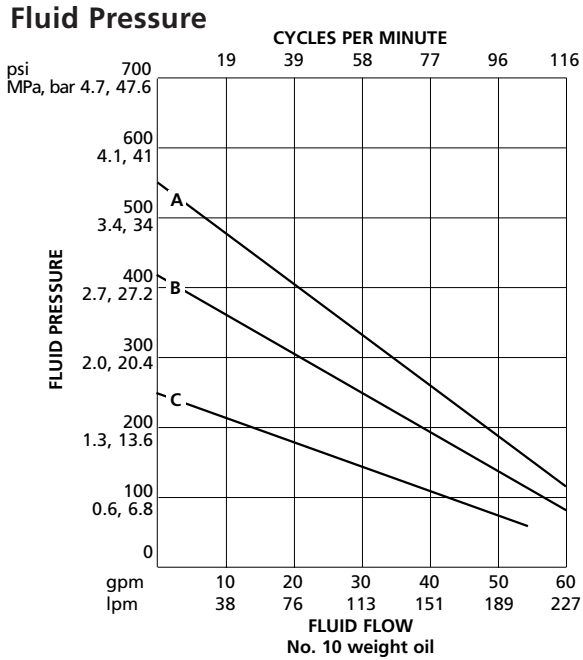

Air Consumption

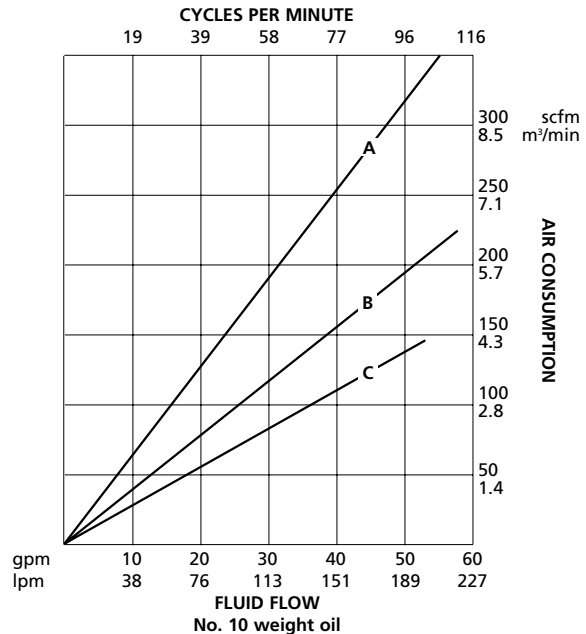

Air Pressures

A = 90 psi (0.6 MPa, 6.3 bar)
 B = 70 psi (0.48 MPa, 4.8 bar)
 C = 40 psi (0.28 MPa, 2.8 bar)
 Fluid tested in no. 10 weight motor oil

Ordering Information for King 6:1 High Flo Pump

Order number includes motor and pump lower assembly

Order Nos.	218-513	218-514
Pump Lower		
Part No.	218-515	218-516
Construction	CS	SST
Standard Piston Seal Repair Kit		
	218-735	218-735
Construction	UHMWPE	UHMWPE
Piston Seal Conversion Kit		
	235-856	235-856
Construction	Teflon®	Teflon
Throat Packing Kits		
All Models		
	218-774 UHMWPE (3 packings)	
	218-733 Teflon (3 packings)	
	218-734 Leather (3 packings)	
	237-566 UHMWPE/Leather conversion (7 packings)	
	237-605 Teflon/Leather conversion (7 packings)	

Motor

220-153: Repair Kit

SERVICE PARTS INFORMATION

Pump Lower Part Nos.	218-515	218-516
Cylinder		
	180-499	180-499
Construction	SST	SST
Intake Valve (order separate part numbers)		
Intake Ball	102-974	110-294
Relief Valve Seat	237-744	237-744
Check Valve (order separate part numbers)		
Check Ball	102-974	110-294
Seat	180-529	180-529

Teflon® is a registered trademark of Du Pont

Accessories

220-581 Pump Floor Stand

218-742 Mounting Stand Kit

For pump and High-Flo surge tanks, below.

High-Flo Surge Tank

Reduces fluid pulsations in the fluid line. Rated 60 gpm (228 lpm)

218-509 CS. Inlet/outlet: 2 npt(f).

238-983 SST. Inlet/outlet: 2 npt(f).

238-984 SST. Inlet/outlet: 2 in. Tri-clamp® compatible.

238-985 SST. Inlet/outlet: 1.5 in. Tri-clamp compatible.

Gun Drop Regulator

214-706 Maximum working pressure: 250 psi (1.7 MPa, 17 bar). Maximum flow: 3 gpm (11.3 lpm). SST. Range: 5-100 psi (0.034-0.7 MPa, 0.34-7 bar).

217-314 Maximum working pressure: 250 psi (1.7 MPa, 17 bar). Maximum flow: 3 gpm (11.3 lpm). SST. Range: 20-160 psi (0.136-1.08 MPa, 1.36-10.8 bar).

Back Pressure Valve

224-486 For shear-sensitive materials. 1-1/2 npt(fbe). Maximum working pressure: 200 psi (1.36 MPa, 13.6 bar). Maximum flow: 20 gpm (75.7 lpm). SST. Range: 0.5-200 psi (0.0034-1.36 MPa, 0.034-13.6 bar).

208-997 For non-shear-sensitive materials. Maximum working pressure: 200 psi (1.36 MPa, 13.6 bar). Maximum flow: 15 gpm (56.7 lpm). SST. Range: 5-180 psi (0.034-1.22 MPa, 0.34-12.24 bar).

220-965 Fluid Pressure Relief Valve

300 psi (2.1 MPa, 21 bar).

224-040 Pump Runaway Valve

Maximum working pressure: 120 psi (0.8 MPa, 8.4 bar). Inlet and outlet: 3/4 npt(f).

915-700 Fluid Drop Line Filter

Maximum working pressure: 500 psi (3.4 MPa, 34 bar). SST. Maximum flow: 3 gpm (11.3 lpm).

217-073 Filter Regulator Lubricator

238-157 Heavy Duty SST Agitator

Drum length. Add extensions, below, for tanks.

Extensions for Agitator

191-920 For total shaft length of 39 in. (990 mm).

191-606 For total shaft length of 48 in. (1218 mm).

Throat Seal Liquid (TSL)

Non-evaporating liquid for wetcups

206-995 1 qt. (0.95 liter)

206-996 1 gal. (3.8 liter)

110-183 90° Street Elbow

For pump inlet and outlet. 2 npt(mxf).

222-955 Anti-Seize Thread Lubricant

Use when repairing SST pumps

Tri-clamp® is a registered trademark of Tri Clover Inc.